

Realization of User-Defined HVDC Converter Models for RTDS using Simulink Real-Time Embedded Coder

Presenter: Deyang Guo

Deyang Guo^{1}, M.H. Rahman¹, G.P. Adam¹, Lie Xu¹, Abdullah Emhemed¹, Graeme Burt¹ and Yash Audichya²*

¹ *University of Strathclyde, Glasgow, UK,*
² *The National HVDC Centre, Glasgow, UK*
deyang.guo@strath.ac.uk

- ❑ Reason
 - Why user-defined MMC model
- ❑ Development process
 - Half-bridge MMC
 - Switching function model
 - Realization in Matlab/Simulink
- ❑ Validation of user-defined model against MMC5 model
 - Three-Phase-to-Ground AC Fault
 - Pole-to-pole DC Fault
- ❑ Conclusion

User-defined MMC model

MMC models from library:

- Processor based model
 - MMC5
 - CHAINV5
- GTFPGA based model
 - The Unified Model (U5)
 - The Generic Model (GM)

User-defined MMC model:

- Flexibility
 - Modelling methods
 - Topologies
 - Configurations
- Parameters
- Control strategies
- Processor assignment

A user-defined processor-based half-bridge MMC model is developed.

Simulation Challenges of MMC

- Large number of SM per arm – modular design & good scalability
- Generate near sinusoidal AC output using low switching frequency

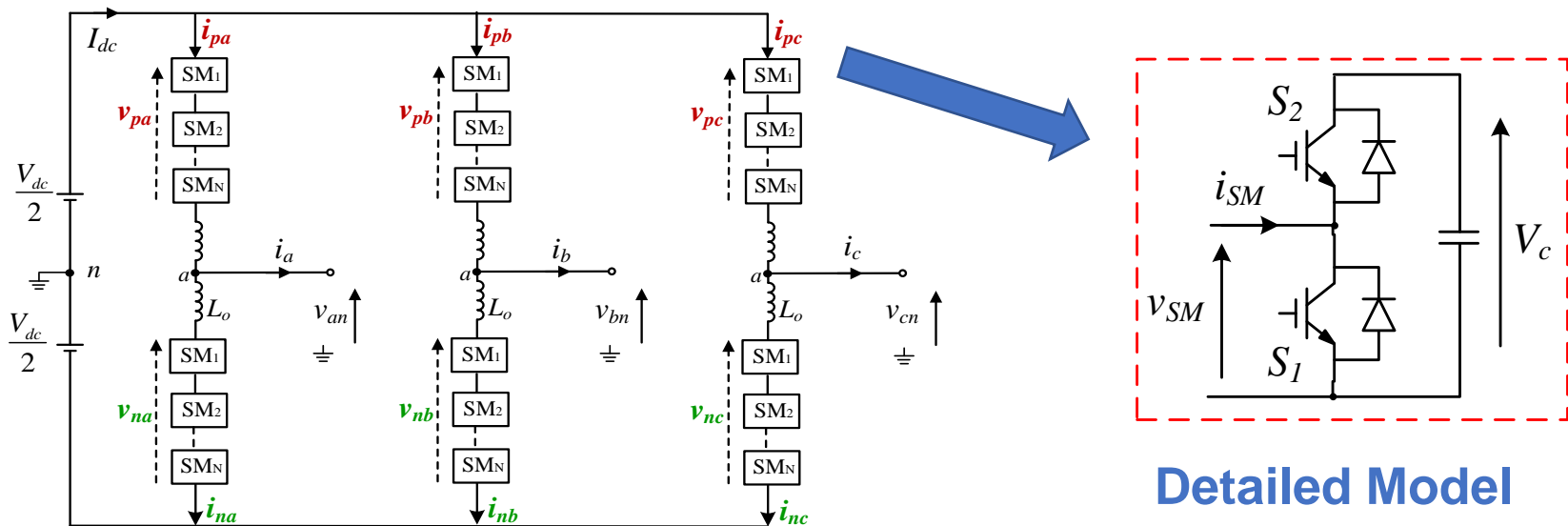

Switching Function Model

- The semiconductor switching devices are represented by ideal switches, where the ON and OFF states are denoted by 1 and 0 respectively.
- Capacitor voltage and current dynamics are expressed in terms of switching functions S_{xi} :

$$v_{mi}(t) = s_{xi} V_{CSMi}(t)$$

$$i_{ci}(t) = s_{xi} I_{arm}(t)$$

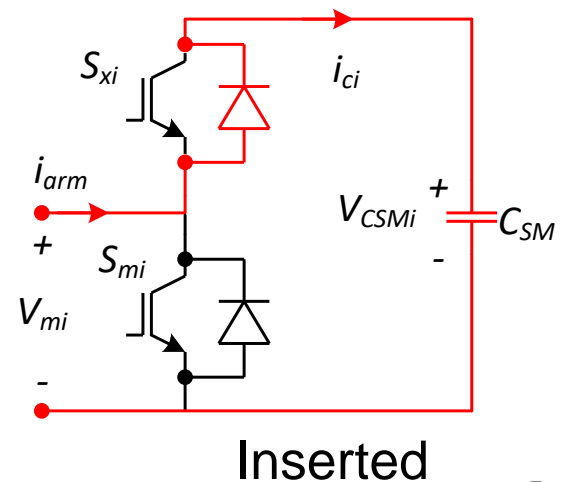
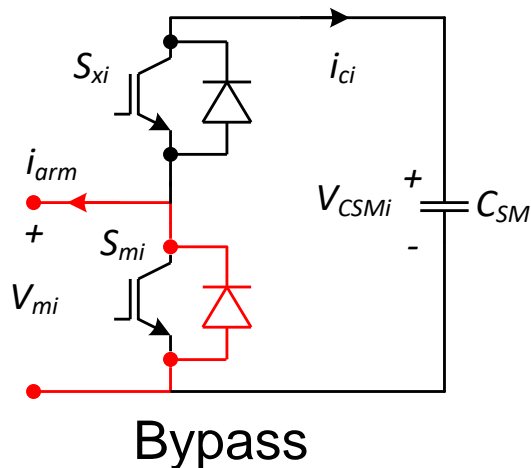

Switching Function Model

- At each time step, the capacitor voltages are updated and arm voltage calculated.
- Simulation speed increased.
- For dealing with converter blocking state, internal diodes and switches are added at each arm.

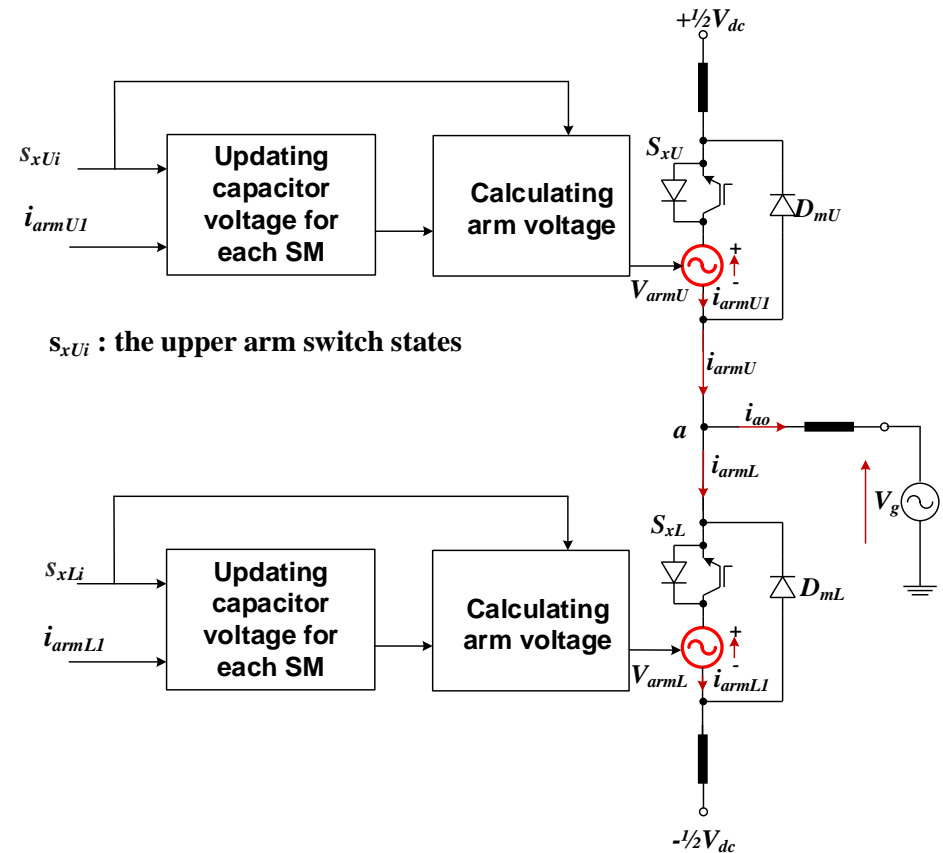

Switching Function Model

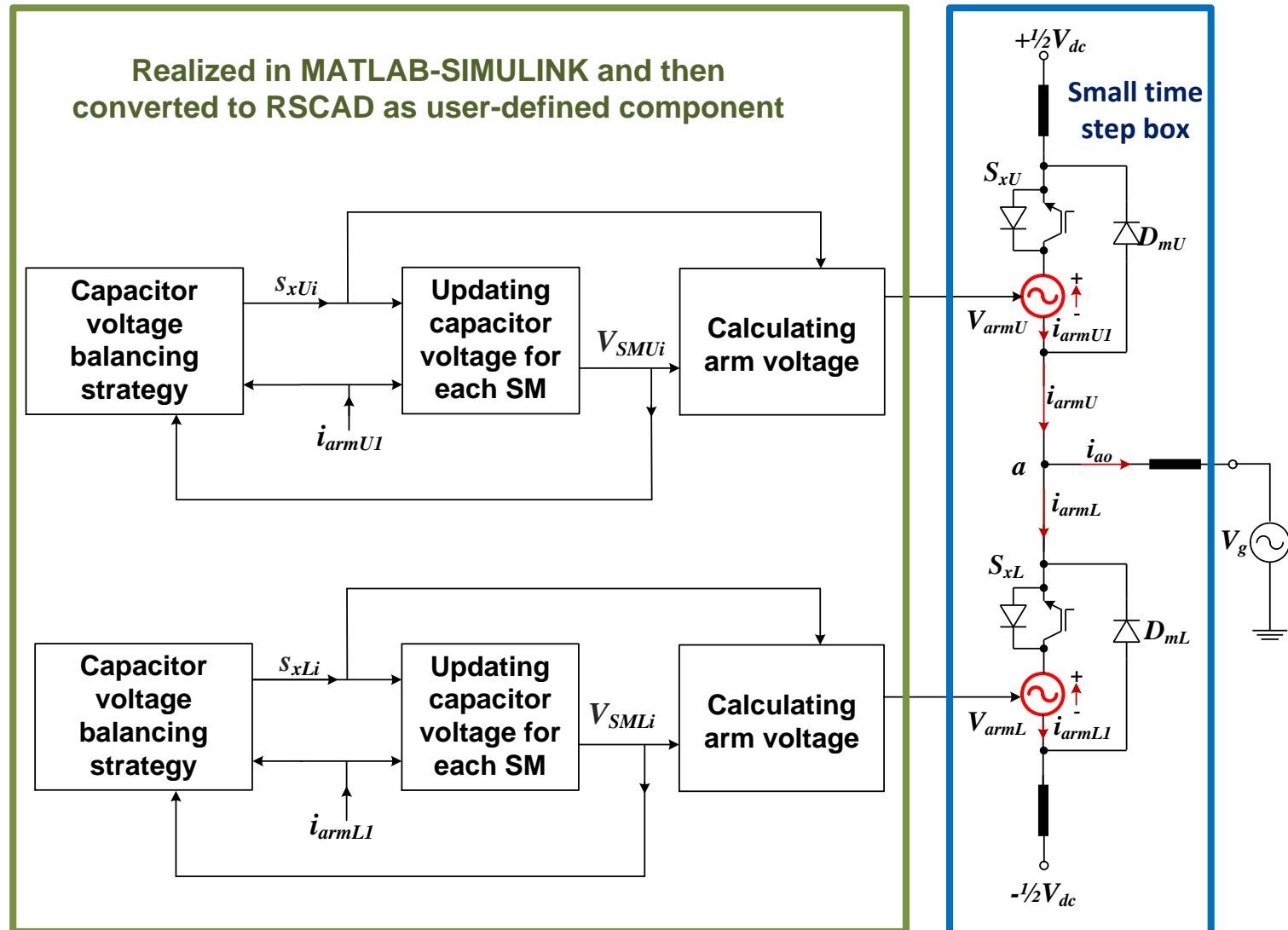

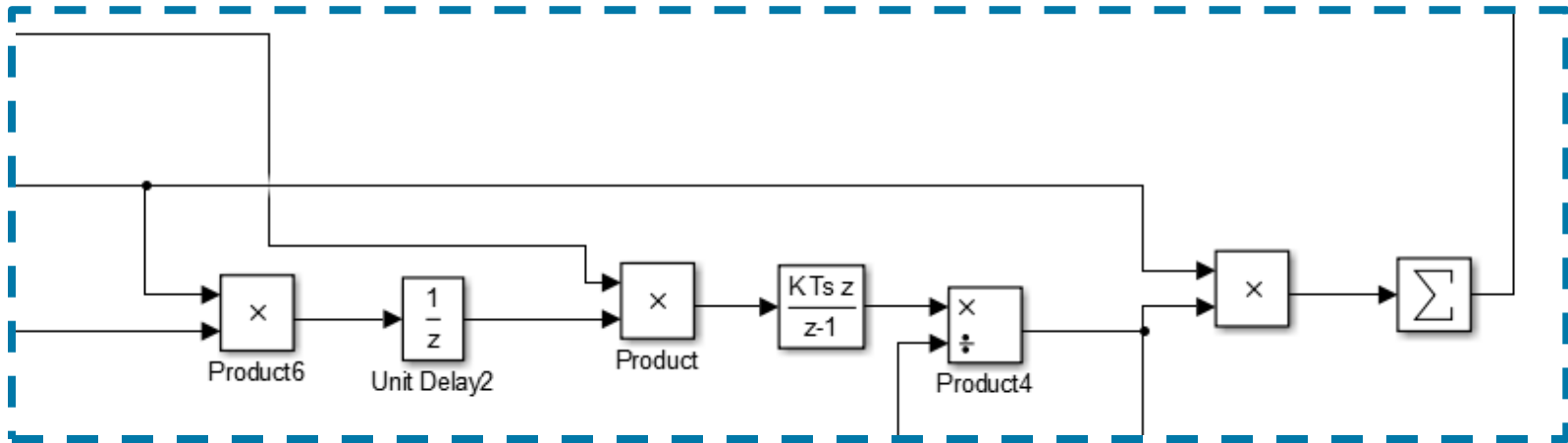

Matlab:

- R2015b
- Model configuration parameters are based on the Simulink-RSCAD conversion tutorial

Switching function modelling method:

- Components from Simulink library
(multiply, delay, integrator)

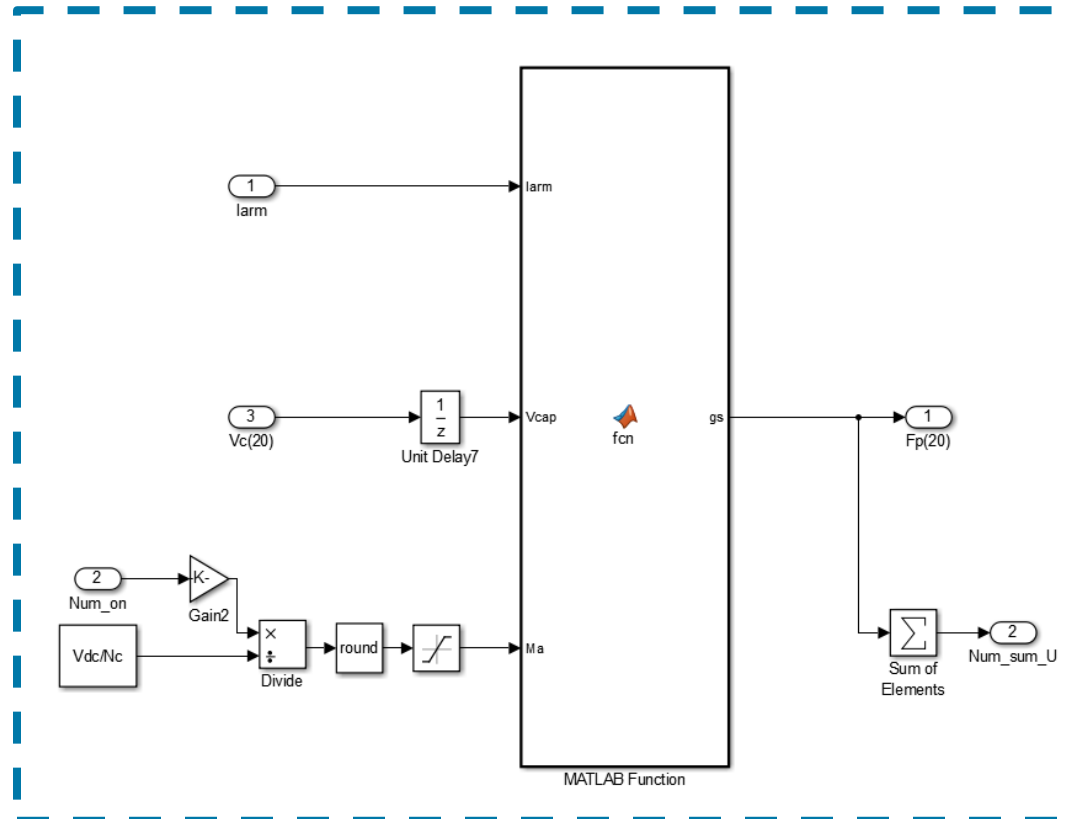

Capacitor voltage balancing control:

- Simple code(21 lines)
- Basic strategy: sort function
- Sorting all capacitor voltages every simulation time step

RSCAD Component Builder

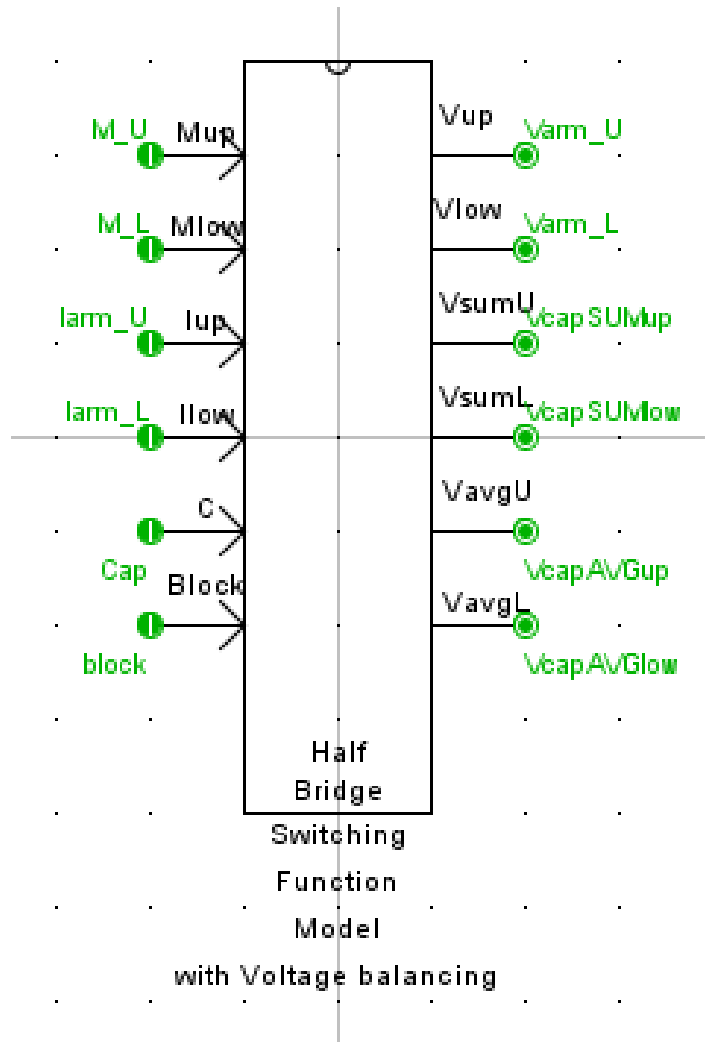

- Tool: Import Simulink model
- Component type: Control
- Inputs and outputs
- 50 μ s simulation time step

Validation against MMC5 model

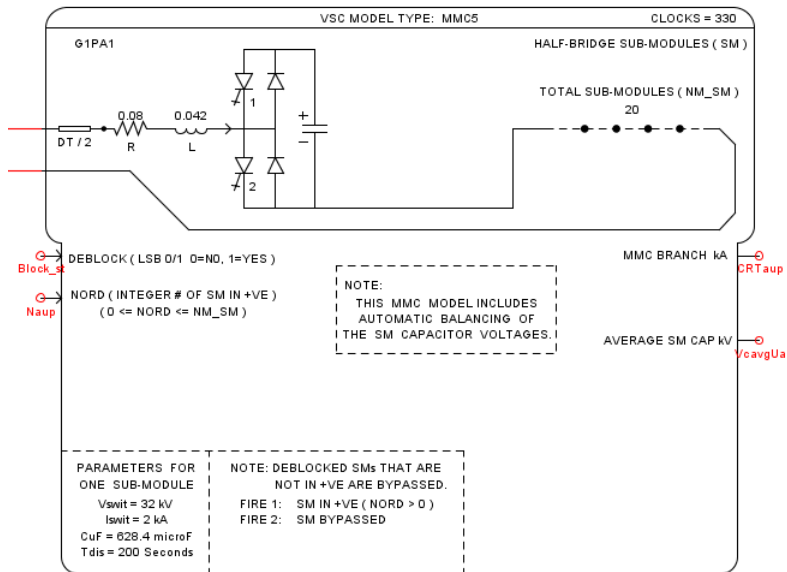

MMC5 model

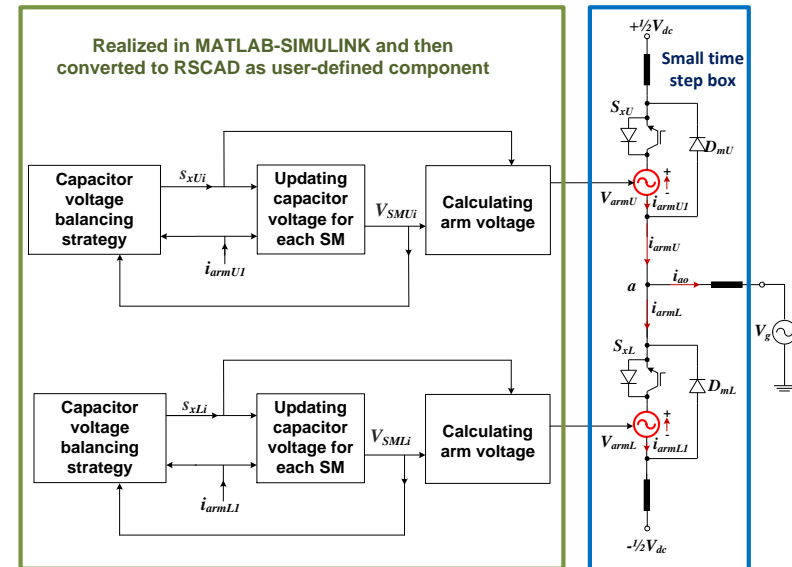

User-defined switching function model

- MMC5 model from RSCAD library is used as the benchmark
- Half-bridge
- 20 SMs per arm
- Same test system

Test System

- Simple one terminal MMC supplied by a DC source
- Converter is in active power control mode
- The SM capacitances are calculated based on the recommended value of 30 kJ/MVA (by ABB*)

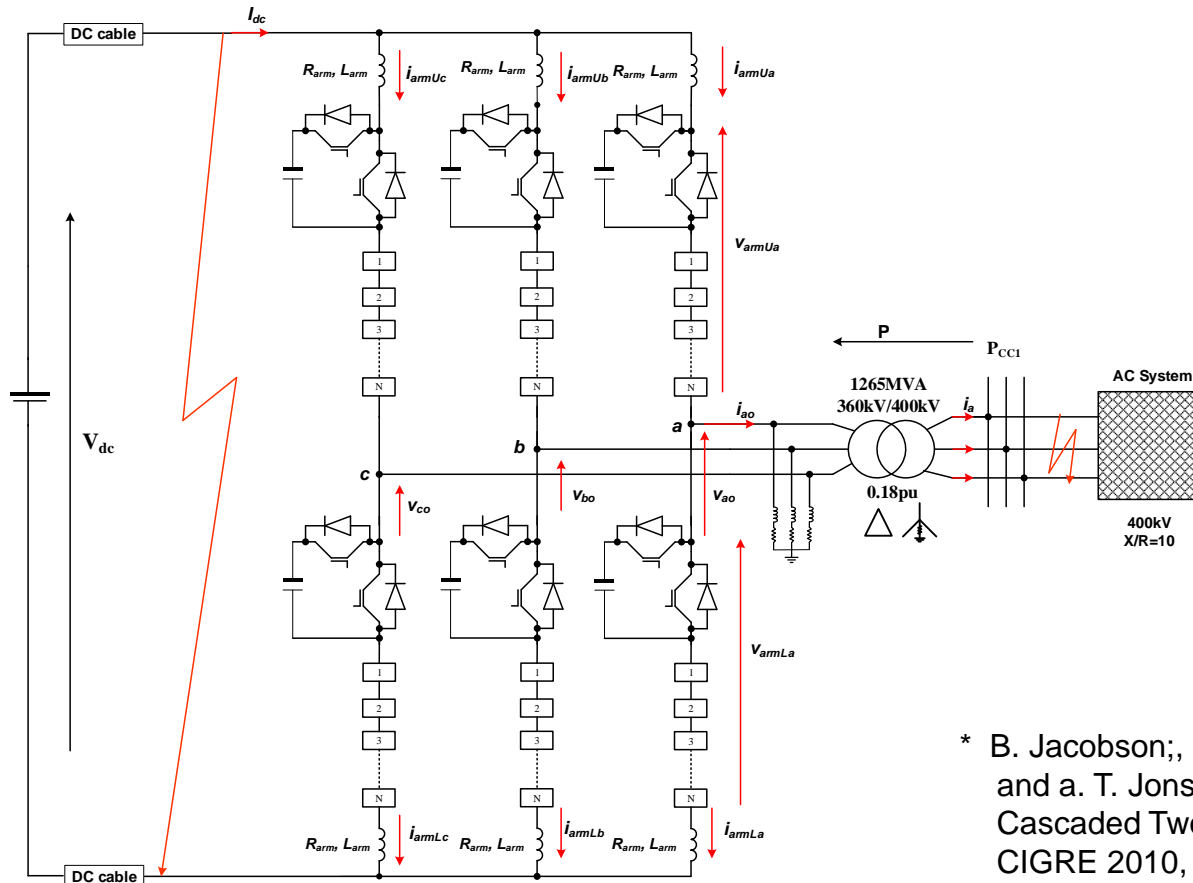

* B. Jacobson;, P. Karlsson;, G.Asplund;, L.Harnnart; and a. T. Jonsson, "VSC-HVDC Transmission with Cascaded Two-level Converters," presented at the CIGRE 2010, 2010.

Table I: Simulation Parameters

Parameters	Value
MMC rated active power (P)	1200MW
MMC nominal dc Voltage (V_{dc})	640kV(± 320 kV)
MMC rated ac output voltage (L-L)	360kV
Arm inductance (L_{arm})	0.13pu
SM capacitance (C_{SM})	20-SM 628 μ F
Nominal Frequency	50Hz
Interfacing transformer voltage ratio	400/360kV
Transformer leakage reactance	0.18pu

Simulation Scenarios:

1. Three-Phase-to-Ground AC Fault
2. Pole-to-pole DC Fault

MMC Control - Overall Control System

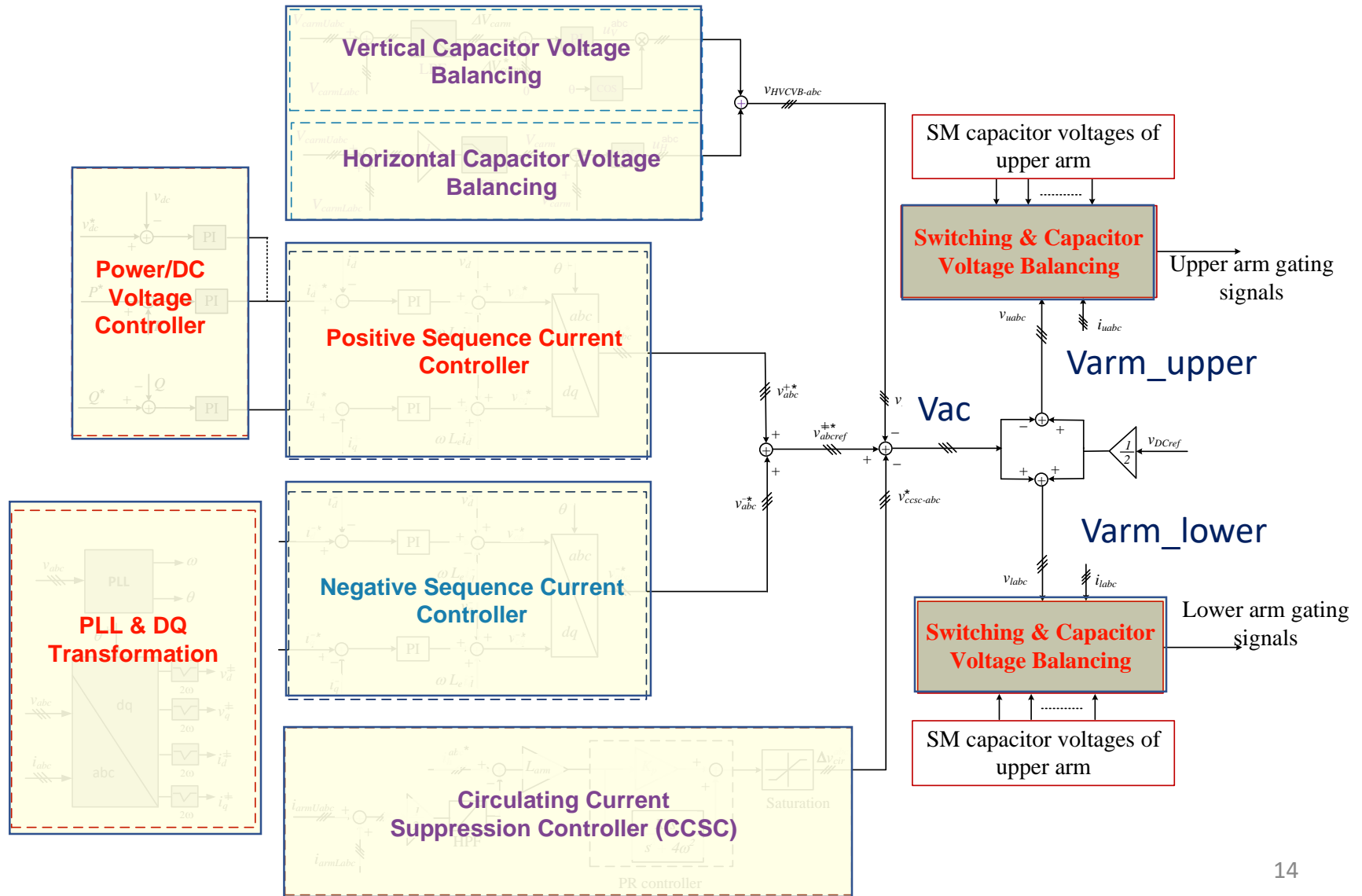

MMC Model Implementations in RTDS

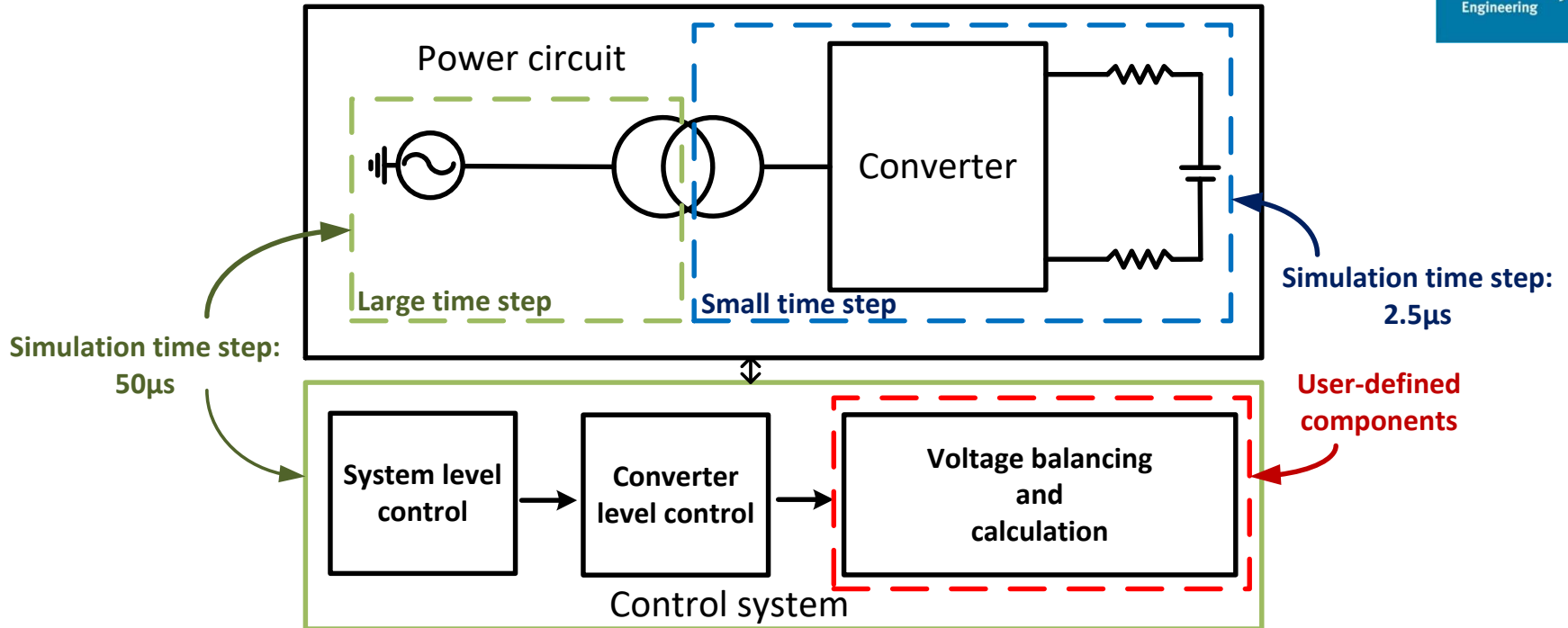

- Part of the MMC models with the requirements of high switching frequency are built in small time step.
- The AC grid source is modelled in a large time step.
- These two parts of power circuit are connected by a interface transformer.
- The model is implemented on **one RTDS rack**, with one PB5 card and 2 GPC cards.

1. Three-Phase-to-Ground AC Fault

- Symmetrical three-phase AC fault happens at $t=4s$ and the fault is cleared after 300ms
 - MMC5: MMC5 model
 - SFM: User-defined switching function model

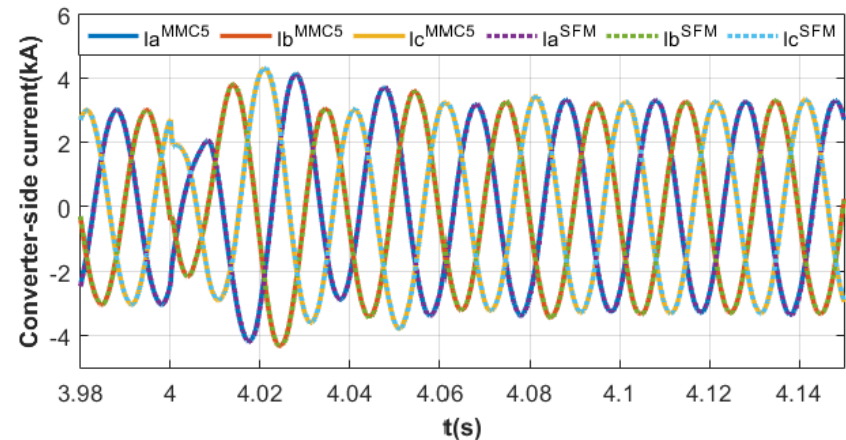
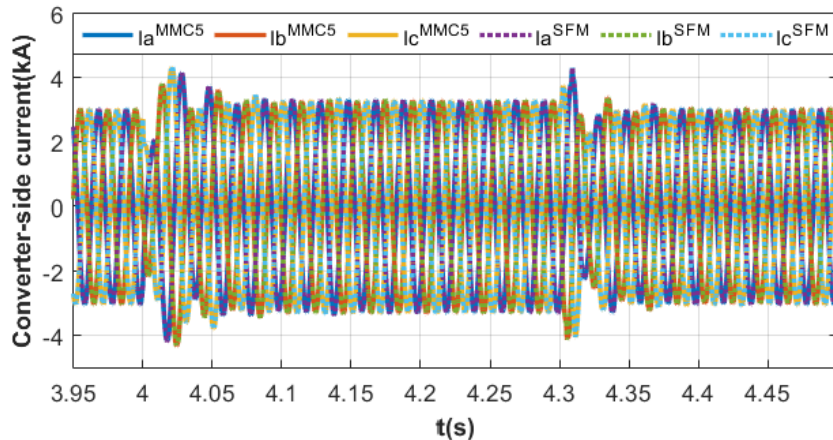

- Converter-side AC currents are well agreed

1. Three-Phase-to-Ground AC Fault

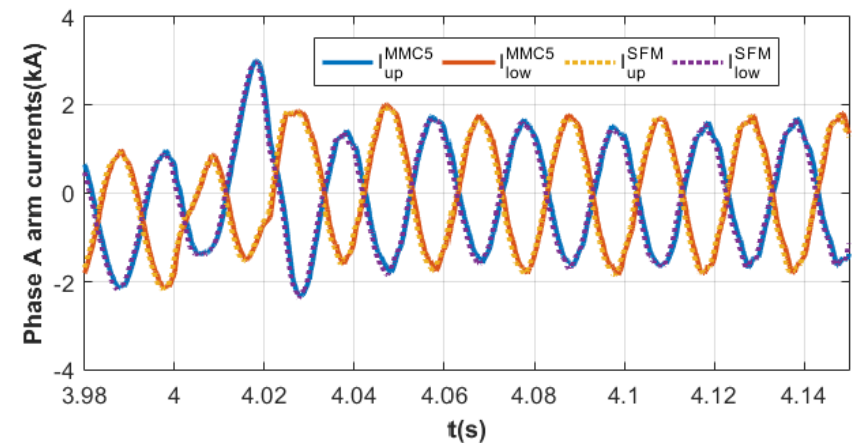
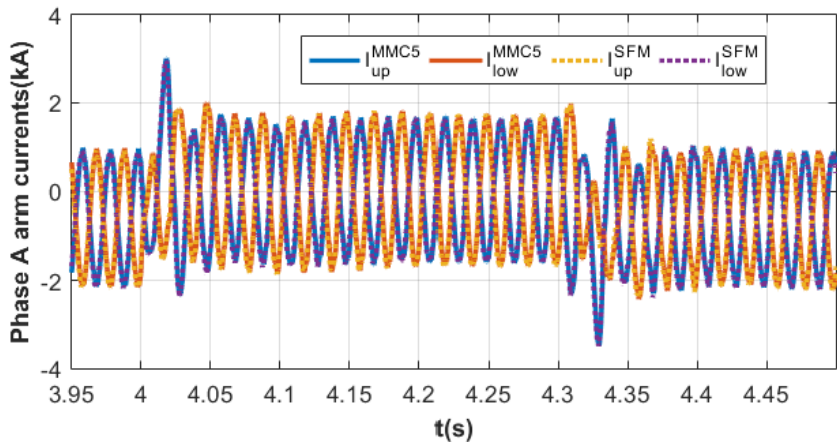
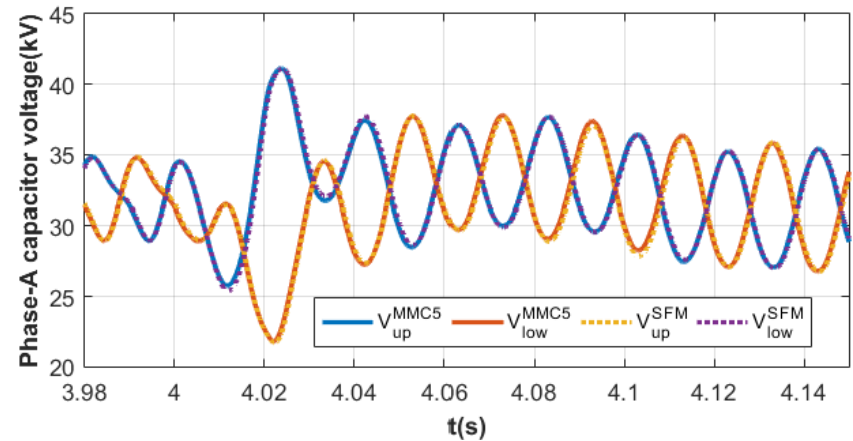
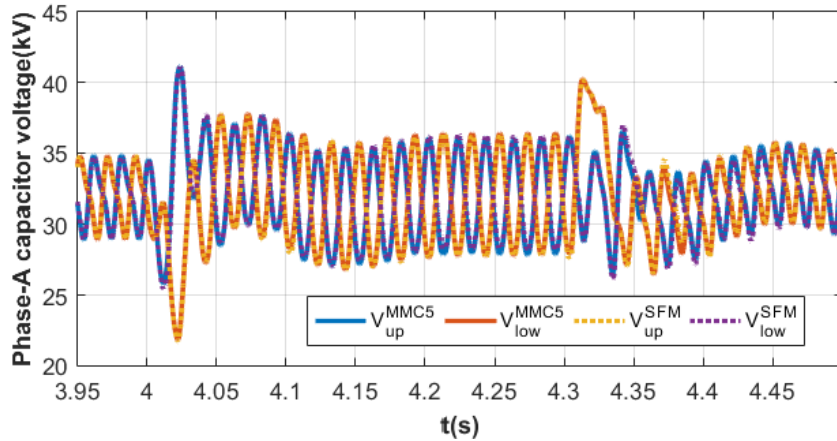

- Average value of capacitor voltages and arm currents are well agreed

2. Pole-to-pole DC Fault

- Fault is applied at $t=6\text{s}$
- Converter blocking is activated $50\mu\text{s}$ after fault inception

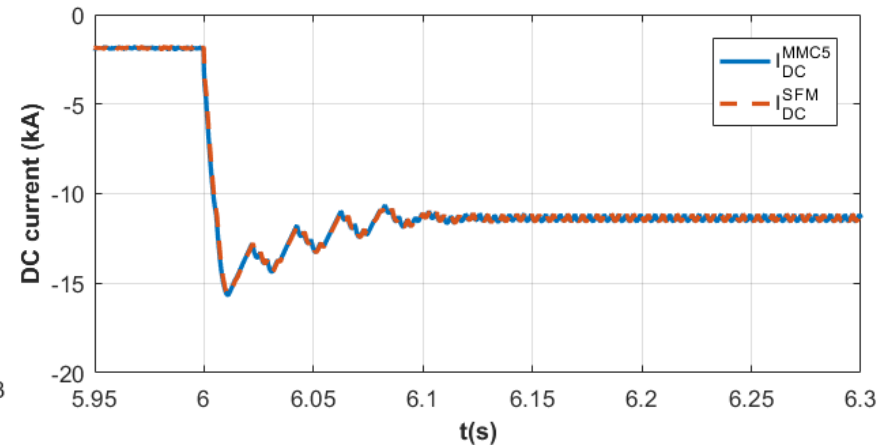
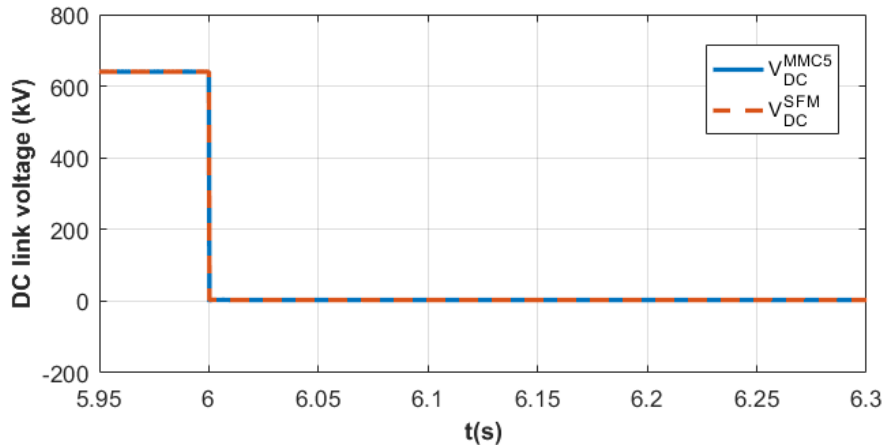

- Observe that both pole-to-pole DC voltages and DC currents are well agreed during steady-state and transition to new steady-state in post-fault.

2. Pole-to-pole DC Fault

- Sum of capacitor voltages and arm currents are well agreed

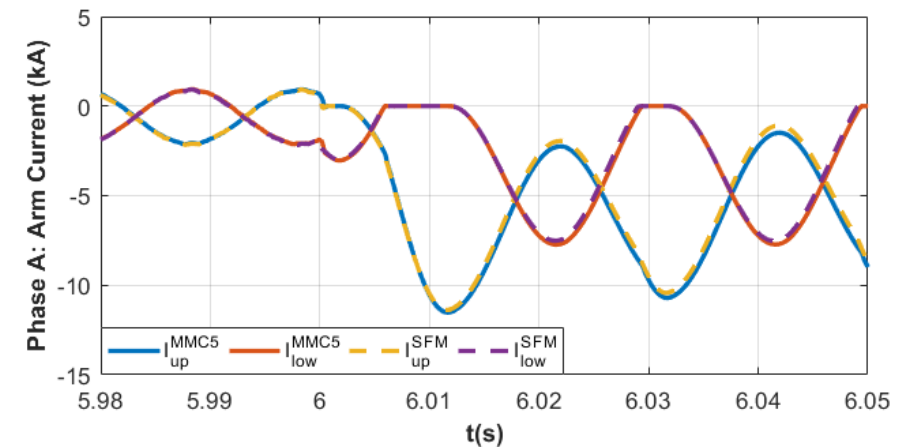
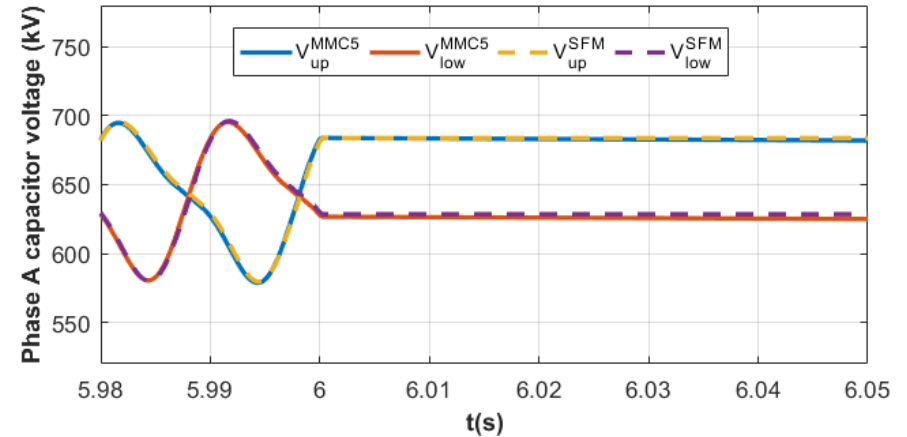
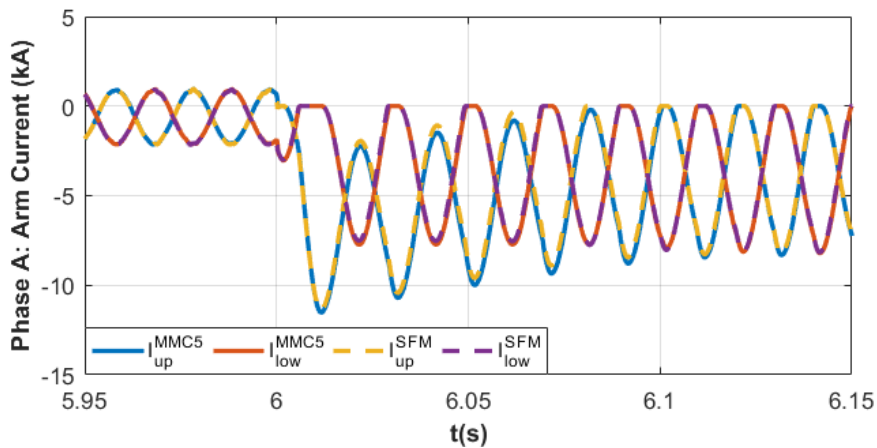

Limitations of this model

- The user-defined model converted from Matlab/Simulink is a processor-based model.
- The total number of SMs per arm is limited by capability of single processor (assigned one processor for capacitor voltage balancing and capacitor voltage calculation of each arm).
- Because of switching function modelling method, this model is not able to be used for simulation of internal faults.

Conclusion

- Matlab/Simulink could be used to speed up the develop of efficient and high fidelity user-defined components for RTDS platform such as HVDC converter models and control systems.
- An illustrative example that implements a user-defined half-bridge MMC model is presented.
- Its results are validated against that of the benchmark model MMC5 from RTDS library.
- Detailed one-to-one comparison of the simulation waveforms show that the user-defined and MMC5 models simulation waveforms are in full agreement to the microscopic level.

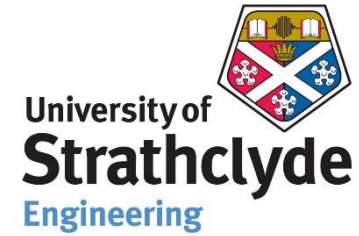

Thank you for your attention!

Question?